

Stay informed Stay empowered

Everything you need to know about your Iowa community, all in one place.



iowapublicnotices.com

RUN IT UNTIL IT SELLS! **FOR SALE BY OWNER!**

Run your 15 word classified photo ad for only **\$29.95**

If it doesn't sell, call us for 30 more days **FREE!**

Your classified photo will reach over 14,000 households!

Call TODAY to run your personalized classified!

Your classified photo ad will appear in:

THE ALGONA REMINDER algona.com KOSSUTH COUNTY ADVANCE

At the end of 30 days, please call Algona Publishing Inc. to renew your classified photo ad for another 30 days. Ad will not automatically renew - you must call to renew - 60 days maximum. Non commercial private party ads only. All ads must be prepaid and no refunds allowed. Only 1 item per ad. Deadline is 1 week prior to first insertion date.

RUN TILL IT SELLS FORM (Please Print)

Name: _____

Address: _____

City: _____ State: _____ Zip: _____

Phone: _____

We Accept:

Acct #: _____ Exp. Date: _____

Name on Card: _____

Signature: _____

Make Checks Payable to: Algona Publishing Company

Description: _____

Price: _____

APPROXIMATELY 15 WORDS MAXIMUM

Bring in or mail this form with picture & payment to
Algona Publishing Co. • 1308 Hwy 18 East
Algona, IA 50511

PROBATE: JUNIOR R. HURLBURT

-17474-
THE IOWA DISTRICT COURT FOR KOSSUTH COUNTY
IN THE MATTER OF THE ESTATE OF JUNIOR R. HURLBURT, Deceased.
CASE NO. ESPR019849
NOTICE OF PROBATE OF WILL, OF APPOINTMENT OF CO-EXECUTORS, AND NOTICE TO CREDITORS

To All Persons Interested in the Estate of Junior R. Hurlburt, Deceased, who died on or about March 31, 2025:

You are hereby notified that on April 10, 2025, the Last Will and Testament of Junior R. Hurlburt, deceased, bearing date of November 23, 2005, the First Codicil to Last Will and Testament bearing date of May 10, 2010, and the Second Codicil to Last Will and Testament bearing date of August 10, 2018, were admitted to probate in the above-named court and that David Hurlburt, Randy Hurlburt, Audrey Thomas and Penny Rahm were appointed Co-Executors of the estate. Any action to set aside the will must be brought in the district court of said county within the later to occur of four months from the date of the second publication of this notice or one month from the date of mailing of this notice to all heirs of the decedent and devisees under the will whose identities are reasonably ascertainable, or thereafter be forever barred.

Notice is further given that all persons indebted to the estate are requested to make immediate payment to the undersigned, and creditors having claims against the estate shall file them with the

clerk of the above named district court, as provided by law, duly authenticated, for allowance, and unless so filed by the later to occur of four months from the date of the second publication of this notice or one month from the date of mailing of this notice (unless otherwise allowed or paid) a claim is thereafter forever barred.

Dated April 11, 2025.

David Hurlburt
504 - 320th St.
Lone Rock, IA 50559
Randy Hurlburt
408 - 370th St.
Fenton, IA 50539
Audrey Thomas
10437 - 5th Ave. Circle
Bloomington, MN 55402
Penny Rahm
509 - 330th St.
Lone Rock, IA 50559

Paul R. Doster, ICIS#: #AT0002104
Attorney for Co-Executors
Fencher, Doster, Buck & Ennen, PLC
106 S. Dodge St.,
Suite 220,
P.O. Box 618
Algona, IA 50511
Date of second publication: April 24, 2025
(No. 17474 published in the Kossuth County (Algona, IA) Advance April 17 and 24, 2025.)

This and other legal notices from around Iowa are searchable at www.iowapublicnotices.com.

COUNCIL PROCEEDINGS: CITY OF FENTON, APRIL 7

-17475-
FENTON CITY COUNCIL MINUTES
Fenton City Council met in regular session Monday, April 7th, 2025 at 7:00 P.M. at Fenton City Hall.
Mayor Gene Miller presided. Meeting was called to order.
Roll Call-Council Members present: Dan Ulfers, Gary Jentz, Ryan Harms, Alex Sauve, Art Pixler.
Absent: None.
Quorum Established.
Others in Attendance: Kaitlyn Bierstedt-City Clerk and one visitor.
Motion made by Pixler and seconded by Sauve to approve the agenda as presented. All ayes. Motion carried.
Motion made by Ulfers and seconded by Jentz to approve the minutes of regular council meeting, March 3rd, 2025. All ayes. Motion carried.
Motion made by Harms and seconded by Jentz to approve the 6:00 P.M. March 31st, 2025 Special Meeting Minutes, as presented. All ayes. Motion carried.
Motion made by Pixler and seconded by Sauve to approve the 6:15 P.M. March 31st, 2025 Special Meeting Minutes, as presented. All ayes. Motion carried.
Motion made by Harms and seconded

by Ulfers to approve the Treasurer's and Financial Reports for March 2025. All ayes. Motion carried.
Motion made by Harms and seconded by Jentz to approve the following bills as presented. All ayes. Motion carried.
Algona Publishing Company, Minutes/Prosed Tax Levy Published 247.29
Alliant Energy, Electricity 1,942.11
Baker & Taylor, Books/DVDs Purchased 331.92
Banyon Data Systems, INC, UB Support & Vault Backup 1,064.00
Coxworth Water Conditioning, Solar Salt Delivered 945.00
Hy-Vee, Amb/ FD Supplies 164.95
Iowa Assoc. of Mun. Utilities, Water Member Dues 677.00
Iowa Dept. of Revenue, Jan. 2025 Water Serv. Excise Tax 582.63
Iowa Dept. of Revenue, Feb. 2025 Water Serv. Excise Tax 512.92
Iowa Dept. of Revenue, Jan.-Dec. 2024 Annual State Sales Tax 791.69
IPERS, Feb. 25-IA Retirement 1,428.32
IRS-EFTPS, Fed./ Med./ S.S Pmt. 1,915.91
Kossuth Co. Sherrif Office, Contract Law Enforcement Pmt. 2,000.00

Kossuth County Auditor 12,848.63
Mar. 25 Landfill Transfer Fees 552.00
MidAmerican Energy, Heat 1,074.13
Municipal Maint. Services, Water Affidavit Operator Services 420.00
New Cooperative. Inc., Gas for Vehicle .. 33,495.66
North Iowa Area Comm. College, Amb.-Class ID# 19827- Ellen Hutchinson 20.00
Nuway- K&H Coop., Fuel Purchased 42.89
Office of Auditor of State, Periodic Examination Fee 1,200.00
State Hygienic Lab, Water Testing 14.50
Team Lab. Chemical Co., Buga Bugs Plus/ Shady Blue Pond Dye 1,215.00
US Postal Service, Post Office Box Renewal 74.00
USDA-RD, Sewer Loan Pmts... 4,130.00
Visual Edge It Inc, Library- Contract Invoice 99.41
Wex Bank, Amb. Fuel Purchased. . 92.39
Payroll, Net Wages 5,892.35
Total Approved Expenses, 304/25 to 04/07/25..... 33,495.66
TOTAL APPROVED DISBURSEMENTS BY FUND:
General..... 12,848.63
Special Revenues..... 3,172.57
Debt Service 00
Enterprise Funds-Water, Wastewater, Solid Waste 16,251.30
Total Disbursements Approved 33,495.66

RECEIPTS SUMMARY-MARCH 2025:
General.....11,263.80
Special Revenues..... 2,483.66
Debt Service Fund..... 144.43
Enterprise Funds-Water, Wastewater, Solid Waste 26,495.04
Total Receipts..... 40,386.93
With Chad not being present Mayor Miller read the Superintendent's report.
Council went over the Water & Solid Waste Report for March 2025. Delinquent bills reviewed. Clerk directed to do standard procedure for all delinquent bills.
On motion by Pixler and seconded by Sauve, meeting adjourned at 7:40 P.M. to regular meeting, Monday, May 5th, 2025 at 7:00 P.M.
(No. 17475 published in the Kossuth County (Algona, IA) Advance April 17, 2025.)

This and other legal notices from around Iowa are searchable at www.iowapublicnotices.com.

NOTICE: GRAIN BIN CLEARANCE GUIDELINES, ALGONA MUNICIPAL UTILITIES

Thinking About Building A Grain Bin?

If you're planning to build or move a grain bin -- either on your property or for someone else -- you need to be familiar with Iowa's law on required distances from overhead electric lines. This law was put into place to provide protection from the hazard of contacting overhead electric lines to anyone working around grain bins with augers, elevators, or other equipment.

The drawings to the right show the specific clearance requirements related to permanently installed augers and portable augers. There must be at least 18 feet between the top of any grain bin and any overhead electrical lines. These distances were developed by the American National Standards Institute. Figure 232.4(b) can be found in the 2017 Edition National Electrical Safety Code (NESC).

As your electric service provider, Algona Municipal Utilities is responsible for ensuring that these specifications are met. In fact, in any situation where minimum clearance requirements are not observed, AMU may refuse electric service.

So if a new grain bin is on your lists of projects, please give AMU a call at (515) 295-3584. We will work with you in developing a site plan for your project.

OUR #1 PRIORITY . . .
Providing You with Safe and Reliable Electric Service!

Grain Bin Clearance Guidelines

Source: The 2017 Edition National Electrical Safety Code (NESC) and the American National Standards Institute (ANSI C2-2017)

- Figs. 234-4(a) Clearance Envelope for Grain Bins filled by permanently installed augers, conveyors or elevators**
- P = probe clearance 5.5m (18 ft.)**
H = horizontal clearance 4.6m (15 ft.)
T = transition clearance
V1 = vertical clearance above a building required by Rule 234C (Table 234-1)
V2 = vertical clearance above land required by Rule 232B (Table 232-1 or 232-2)

Figs. 234-4(b) Clearance Envelope for Grain Bins filled by portable augers, conveyors or elevators

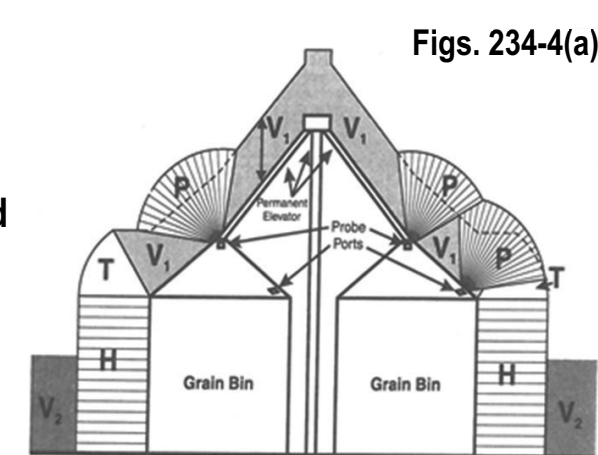
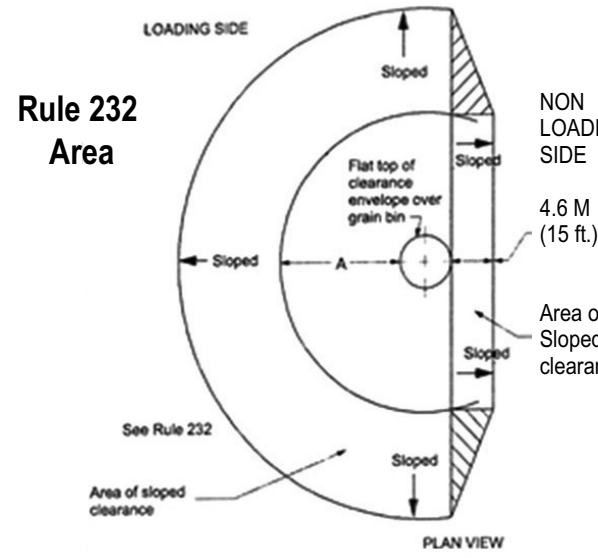
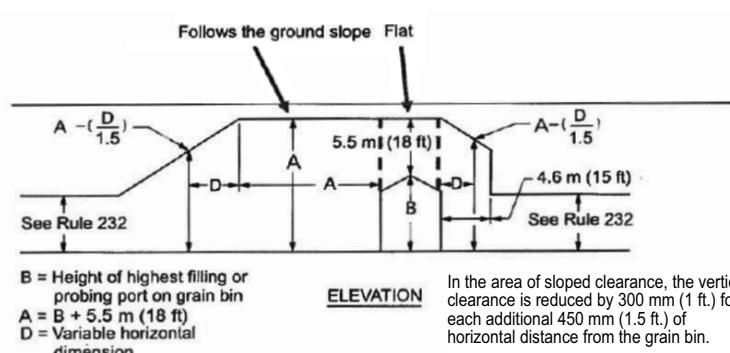

Algona Municipal Utilities

104 West Call St. • PO Box 10 • Algona, Iowa 50511
Phone: 515-295-3584 • Fax: 515-295-3364
email: amu@netamu.com
www.netamu.com